

If you want a pump that lasts.

ebm-papst Alpha Pump

replacing ebm 40 JB

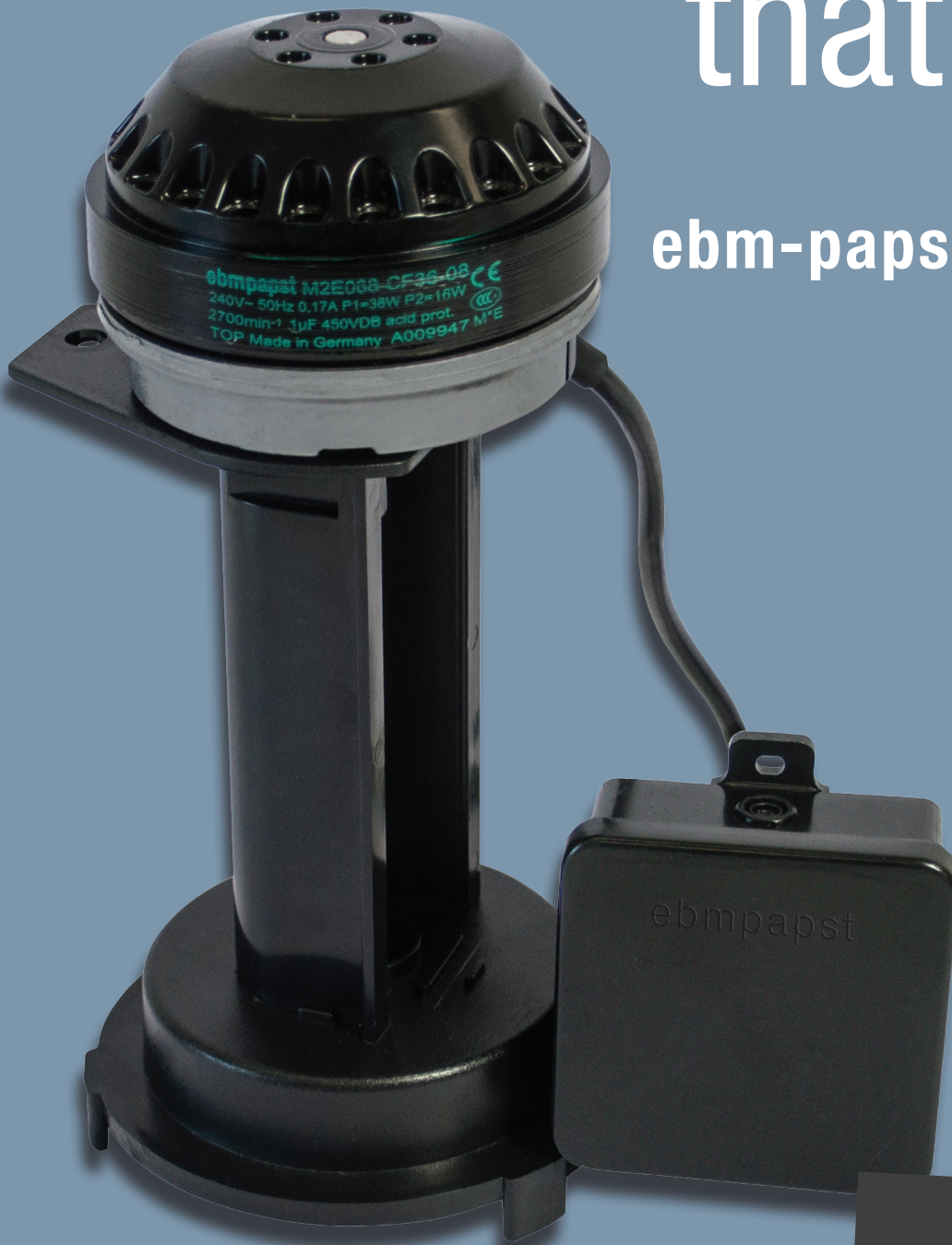

2 years warranty
The best in the market

The new **ebm-papst Alpha Pump**: the reliable, efficient, replacement of your existing evap pump.

We have taken our proven ebm 40 JB pump design and improved it significantly. The powerful split-capacitor motor with high starting torque supports easy starts even after long off-periods. It is protected and self-cooling for longer lifetime. The improved design gives increased performance while using 20% less energy than the comparable evap pumps in the market. It replaces most other pumps on the market and its single point mounting enables quick exchange.

The new **ebm-papst Alpha pump** – the technology leader in evaporative cooling. Find out more at www.ebmpapst.com.au



The engineer's choice.

ebmpapst
A&NZ

Benefits at a glance

- Reliable external rotor motor
- Efficient – up to 20% less energy use
- Performance improved by 20%*
- Easy replacement of most evap pumps on the market
- Exclusive proven design for harsh Australian conditions
- Environmentally friendly: 30% recycled plastic
- Low draft - requires minimum of only 57mm water depth
- 2 year warranty

*measured at 1500-2000mm head

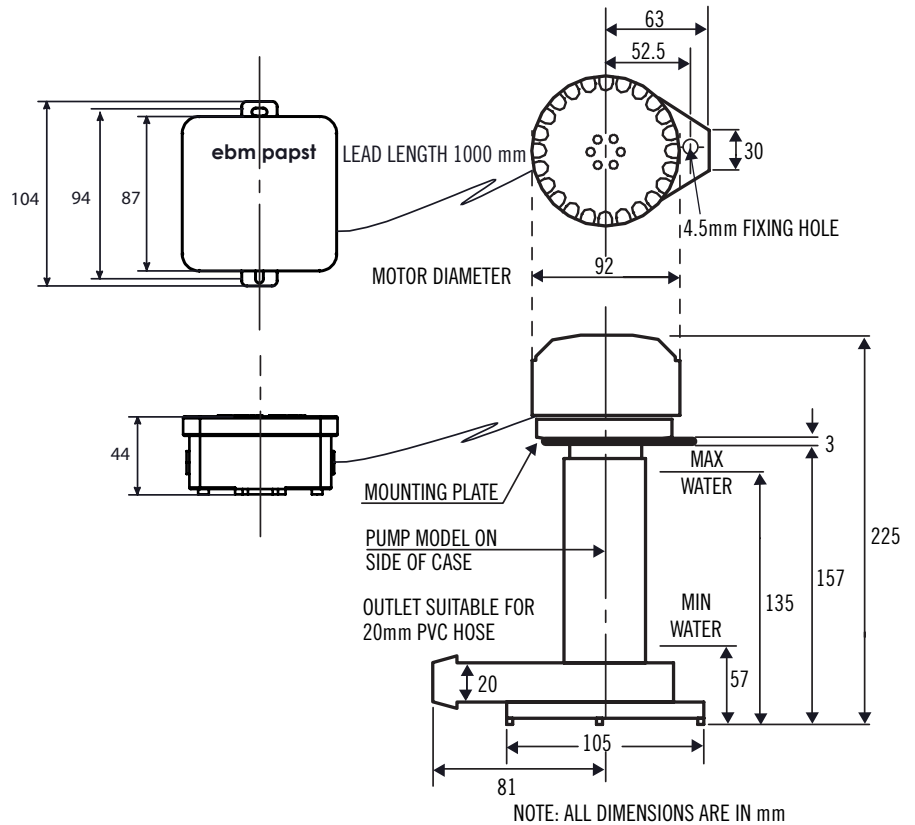

Technical Data**

Model	Power supply	Watts	Flow l/min at 1m head	Flow l/min at 2m head	Motor	Bearings
ebm Alpha	240V/50Hz	50	32	25	External rotor motor	Ball

** Typical data which can vary by location and filter material.

Distributed By:



Freephone 0508 634 341 | Fax 09 634 7417

7 Monier Pl, Mt Wellington, Auckland 1060, New Zealand